

CAD FILE:

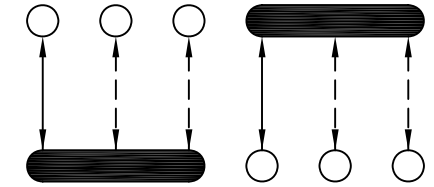

SCHEMATIC (SHORTING)

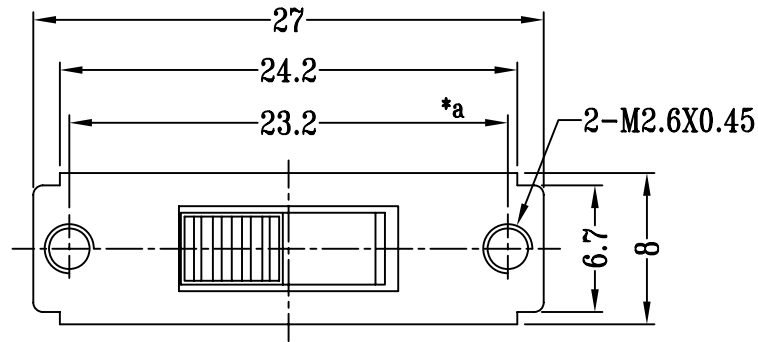
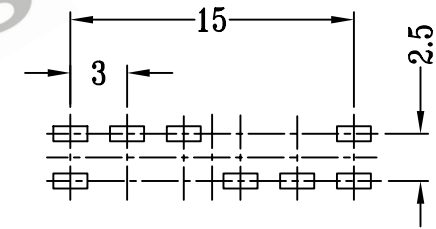
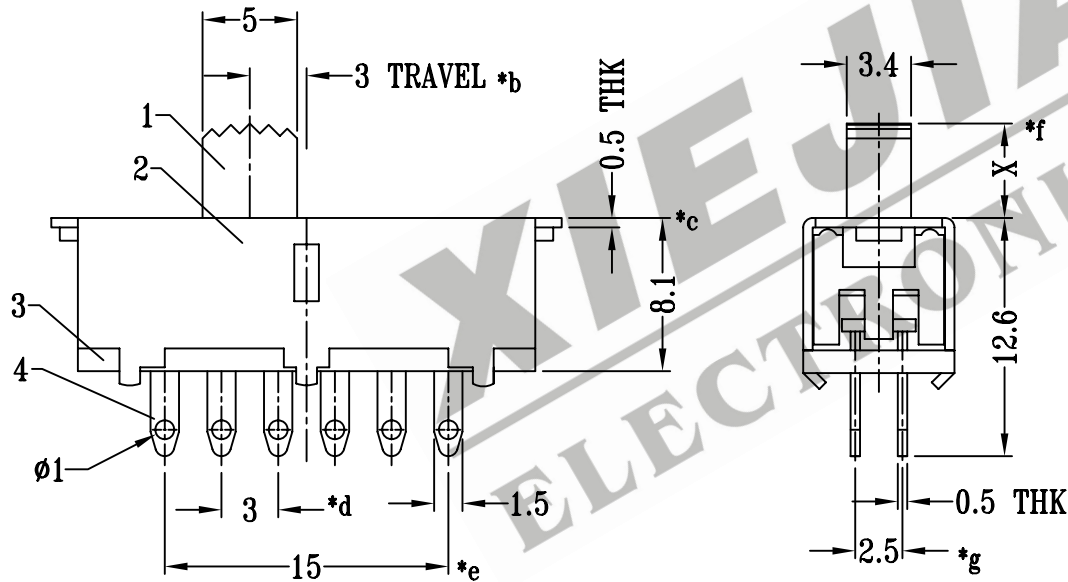

P.C.B LAYOUT

注：“*”表示关键尺寸（7个）

NO.	PARTS	MATERIALS	Q'TY	FINISH	TOLERANCE UNLESS SPECIFIED	SHENZHEN XIEJIA ELECTRONICS CO.,LTD.				
8						TITLE : VERTICAL SLIDE SWITCH				
7	STEEL BALL	STEEL	2	NATURAL	WITHIN: 1.5±0.1mm OVER : 1.5±0.2mm					UNIT : mm
6	SPRING	STEEL WIRE	3	TEMPER		ISSUE	DATE	DESCRIPTIONS OF REVISION		
5	CONTACT CLIP	BRASS STRIP	2	Ag PLATED				APPD.		
4	TERMINAL	BRASS STRIP	8	Ag PLATED OVER Ni PLATED				SCALE: 5:2		
3	BASE	PHENOLIC RESIN	1	BLACK				DWN.	ZHOUYU	2003-9-18
2	FRAME	STEEL STRIP	1	BLACK				CHK'D	FANGYING	2003-9-18
1	KNOB	POM	1	BLACK				APPD.	KANGXINAN	2003-9-18
ALL MATERIALS MUST BE COMPLIANT TO ROHS										